

RETAIL AIR SYSTEMS

P.O. Box 21532
 Chattanooga, TN 37424
 Phone: (800) 245-8104 Fax: (423) 553-1008

APPROVED BY: _____

DATE APPROVED: _____

CPES-2 Conventional Roof Equipment Supports

STANDARD FEATURES

1. 18 Ga. Galvanized Steel Construction.
2. Fully Welded One-Piece Construction.
3. Prime Painted after Fabrication.
4. Full Depth Internal C-Channel Reinforcing on 12" Centers.
5. 6" Spreader Channels on 12" Centers.
6. Counterflashing Attached with Tek-Screws & Neoprene Washers.
7. Pressure-Treated 2 x 4 Wood Nailer (3 1/2" Width).
8. Fully Mitered and Welded 3" Cant.

OPTIONS

- 1.
- 2.
- 3.
- 4.

PROJECT NAME: _____

CITY, STATE: _____

CUSTOMER: _____

JOB NUMBER: _____

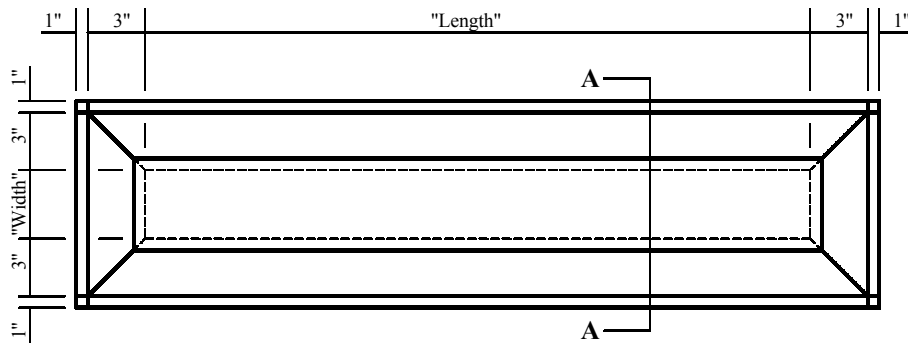

PLAN VIEW

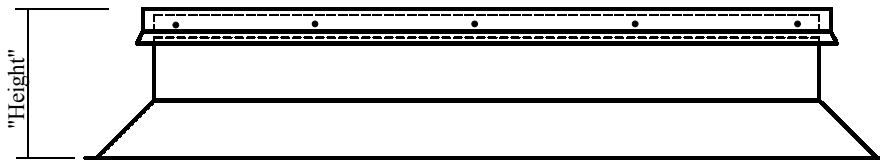

ELEVATION

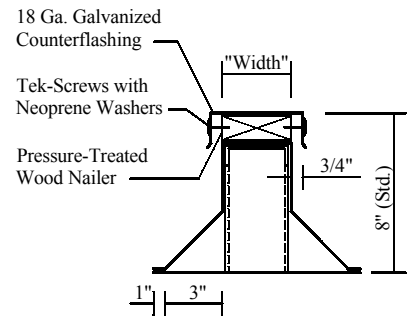

SECTION A-A

QUANTITY	LENGTH	WIDTH	HEIGHT	TAG