

# RETAIL AIR SYSTEMS

P.O. Box 21532  
 Chattanooga, TN 37424  
 Phone: (800) 245-8104 Fax: (423) 553-1008

APPROVED BY: \_\_\_\_\_

DATE APPROVED: \_\_\_\_\_

## CPES-3 Conventional Roof Equipment Supports

### STANDARD FEATURES

1. 18 Ga. Galvanized Steel Construction.
2. Fully Welded One-Piece Construction.
3. Prime Painted after Fabrication.
4. Full Depth Internal C-Channel Reinforcing on 12" Centers.
5. 6" Spreader Channels on 12" Centers.
6. Counterflashing Attached with Tek-Screws & Neoprene Washers.
7. Pressure-Treated 2 x 4 Wood Nailer (3 1/2" Width).

### OPTIONS

- 1.
- 2.
- 3.
- 4.

PROJECT NAME: \_\_\_\_\_

CITY, STATE: \_\_\_\_\_

CUSTOMER: \_\_\_\_\_

JOB NUMBER: \_\_\_\_\_

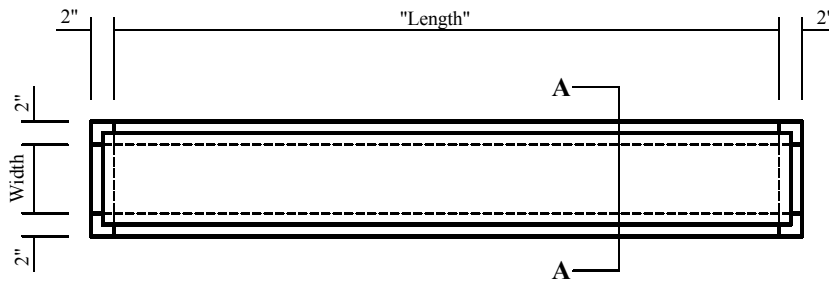

**PLAN VIEW**

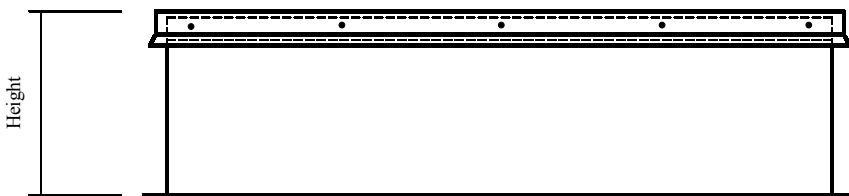

**ELEVATION**

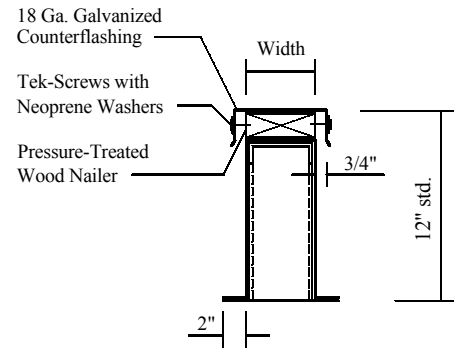

**SECTION A-A**

QUANTITY	LENGTH	WIDTH	HEIGHT	TAG