

RETAIL AIR SYSTEMS

P.O. Box 21532
 Chattanooga, TN 37424
 Phone: (800) 245-8104 Fax: (423) 553-1008

APPROVED BY: _____

DATE APPROVED: _____

CPM-3 (Insulated) Metal Bldg. Roof Curb

STANDARD FEATURES

1. 18 Ga. Prime Galvalume Steel Construction.
2. Corners Mitered and Welded Watertight.
3. Curbs Prime Painted after Fabrication.
4. Water Cricket.
5. 8" Minimum Height.
6. Internal Angle Reinforcing.
7. 1 1/2" Thick, 3# Density Fiberglass Insulation.

OPTIONS

- 1.
- 2.
- 3.
- 4.

PROJECT NAME: _____

CITY, STATE: _____

CUSTOMER: _____

JOB NUMBER: _____

Note: The Front, Rear and Side Flanges Fit Over the Roof Panel

CLIPS TO MATCH THIS ROOF PANEL _____

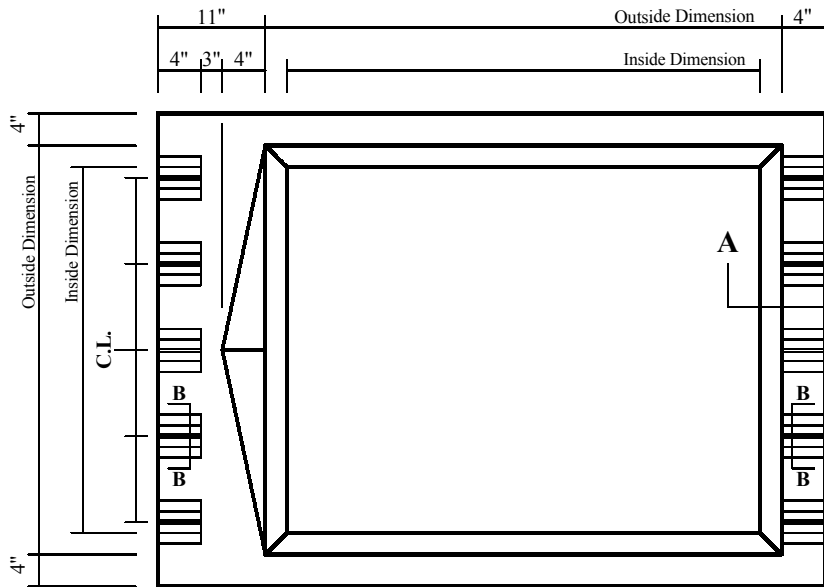

Number of Upper Clips Per Curb _____
 Number of Lower Clips Per Curb _____

"R" PANEL "SSR" PANEL "T" PANEL

SECTION B-B _____

PLAN VIEW

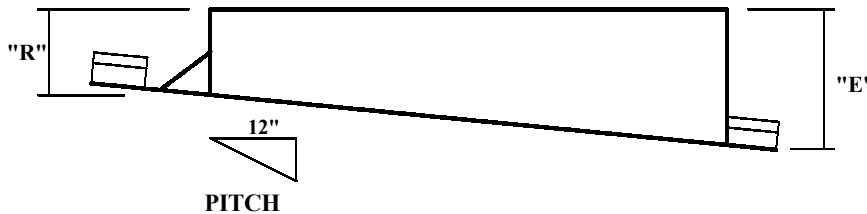

ELEVATION

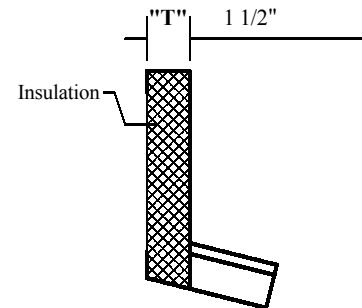

SECTION A-A

SECTION C-C

QUANTITY	INSIDE DIMENSION	OUTSIDE DIMENSION	"R"	"E"	"T"	TAG
	x	x				

RETAIL AIR SYSTEMS

P.O. Box 21532
 Chattanooga, TN 37424
 Phone: (800) 245-8104 Fax: (423) 553-1008

APPROVED BY: _____

DATE APPROVED: _____

CPM-3 (Insulated) Ridge Mounted Metal Bldg. Roof Curb

STANDARD FEATURES

1. 18 Ga. Prime Galvalume Steel Construction.
2. Corners Mitered and Welded Watertight.
3. Curbs Prime Painted after Fabrication.
4. 8" Minimum Height.
5. Internal Angle Reinforcing.
6. 1 1/2" Thick, 3# Density Fiberglass Insulation.

OPTIONS

- 1.
- 2.
- 3.
- 4.

PROJECT NAME: _____

CITY, STATE: _____

CUSTOMER: _____

JOB NUMBER: _____

Note: The Front, Rear, and Side Flanges Fit Over the Roof Panel

CLIPS TO MATCH THIS ROOF PANEL _____

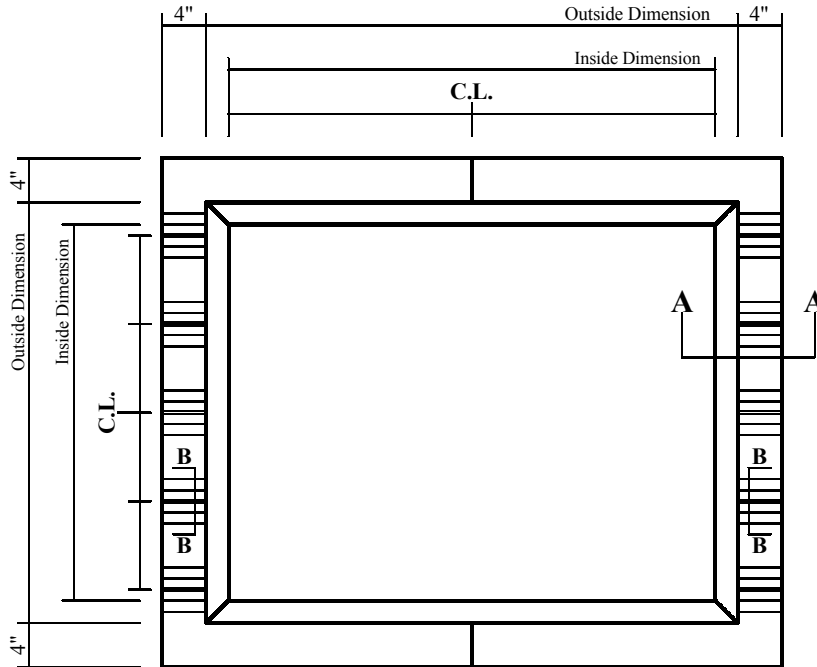

PLAN VIEW

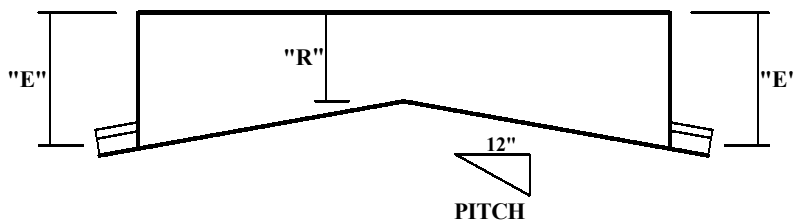

ELEVATION

Number of Over Clips Per Curb _____

"R" PANEL "SSR" PANEL "T" PANEL

SECTION B-B
 (Over-Clips)

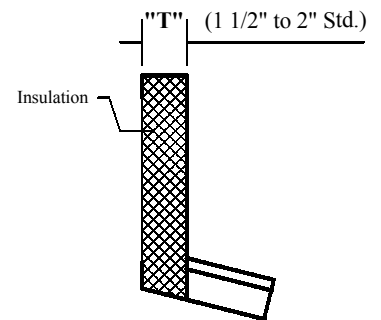

SECTION A-A

QUANTITY	INSIDE DIMENSION	OUTSIDE DIMENSION	"R"	"E"	"T"	TAG
	x	x				