

RETAIL AIR SYSTEMS

P.O. Box 21532
 Chattanooga, TN 37424
 Phone: (800) 245-8104 Fax: (423) 553-1008

APPROVED BY: _____

DATE APPROVED: _____

CPM-9 (Insulated) (1-Piece) Metal Bldg. Roof Curb

STANDARD FEATURES

1. 18 Ga. Prime Galvalume Steel Construction.
2. Corners Mitered and Welded Watertight.
3. Curbs Prime Painted after Fabrication.
4. Water Cricket.
5. 8" Minimum Height.
6. No Front Clips.
7. Internal Angle Reinforcing
8. 1 1/2" Thick, 3# Density Fiberglass Insulation.

OPTIONS

- 1.
- 2.
- 3.
- 4.

PROJECT NAME: _____

CITY, STATE: _____

CUSTOMER: _____

JOB NUMBER: _____

Note: The Front Flange Fits Under the Roof Panel
 The Rear and Side Flanges Fit Over the Roof Panel

CLIPS TO MATCH THIS ROOF PANEL _____

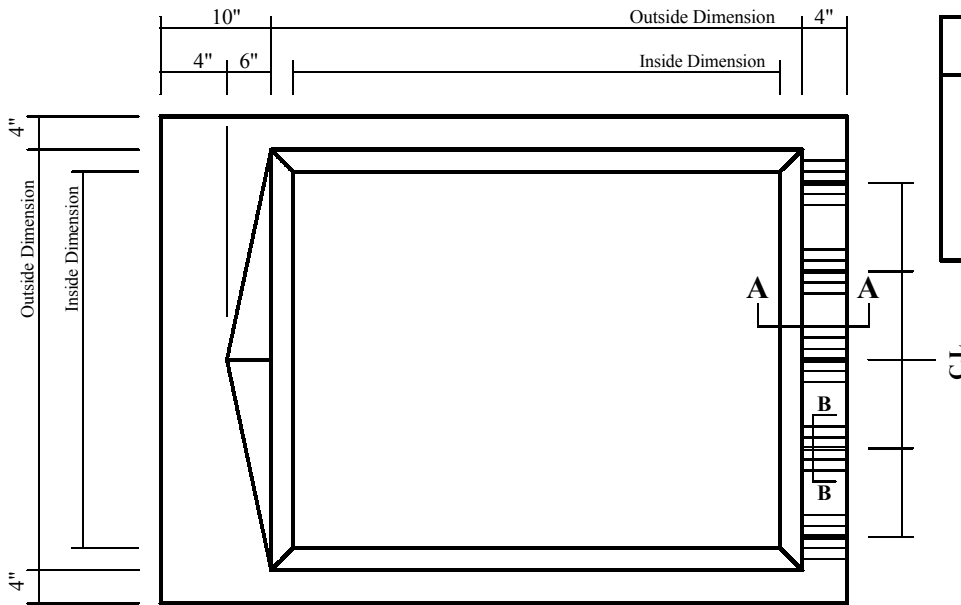

PLAN VIEW

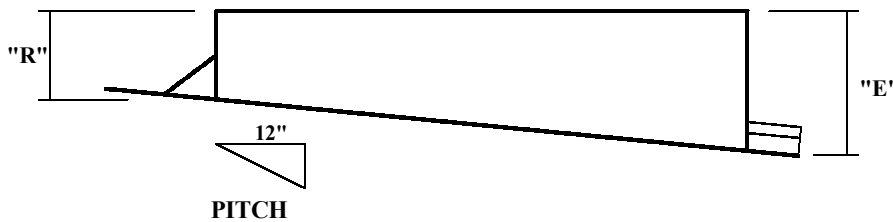
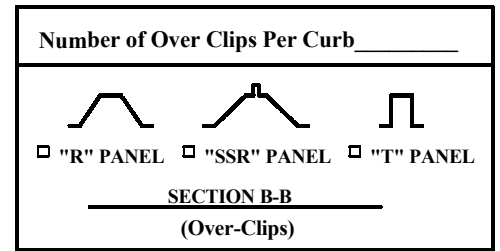

ELEVATION

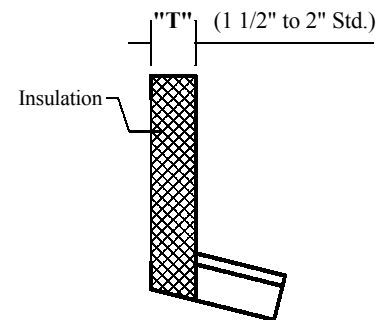

SECTION A-A

QUANTITY	INSIDE DIMENSION	OUTSIDE DIMENSION	"R"	"E"	"T"	TAG
	x	x				

RETAIL AIR SYSTEMS

P.O. Box 21532
 Chattanooga, TN 37424
 Phone: (800) 245-8104 Fax: (423) 553-1008

APPROVED BY: _____

DATE APPROVED: _____

CPM-9 (Insulated) (2-Piece) Metal Bldg. Roof Curb

STANDARD FEATURES

1. 18 Ga. Prime Galvalume Steel Construction.
2. Corners Mitered and Welded Watertight.
3. Curbs Prime Painted after Fabrication.
4. (Separate) 14 Gauge Water Panel.
5. 8" Minimum Height.
6. No Front Clips.
7. Internal Angle Reinforcing
8. 1 1/2" Thick, 3# Density Fiberglass Insulation.

OPTIONS

- 1.
- 2.
- 3.
- 4.

PROJECT NAME: _____

CITY, STATE: _____

CUSTOMER: _____

JOB NUMBER: _____

**Note: The Front Diverter Panel Fits Under the Roof Panel
 The Curb Flanges Fit Over the Roof Panel**

CLIPS TO MATCH THIS ROOF PANEL _____

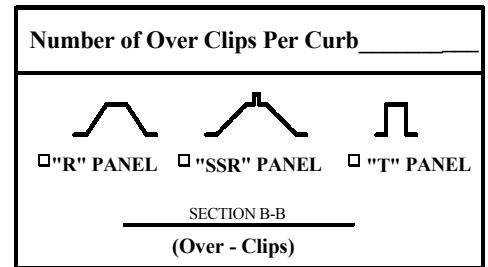
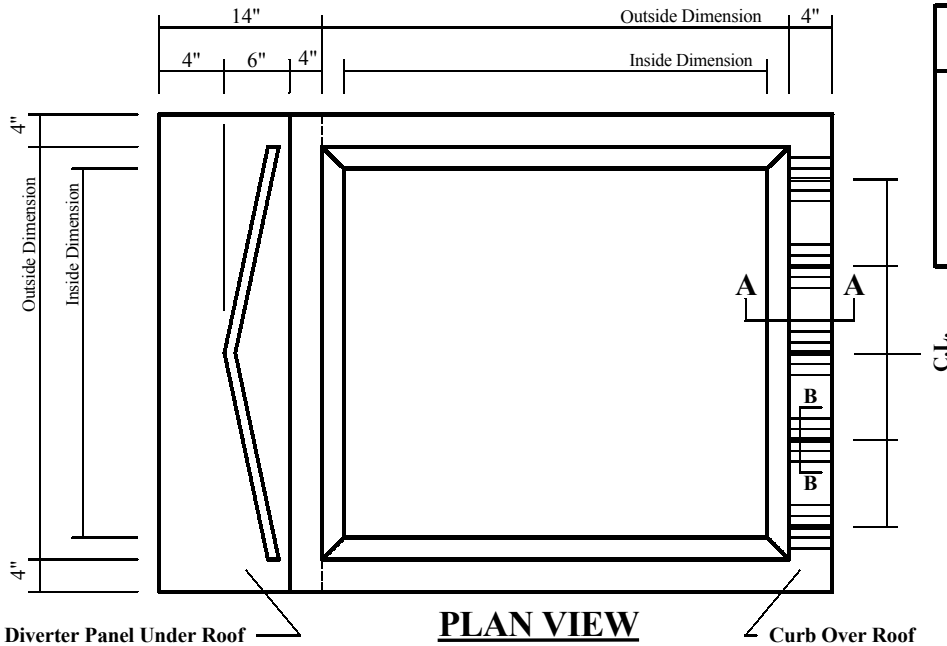

Diverter Panel Under Roof

Curb Over Roof

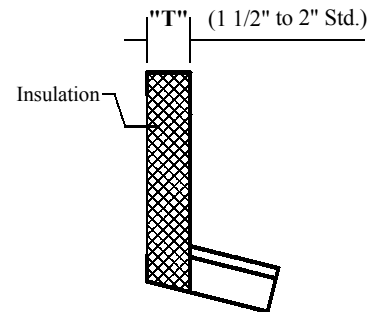
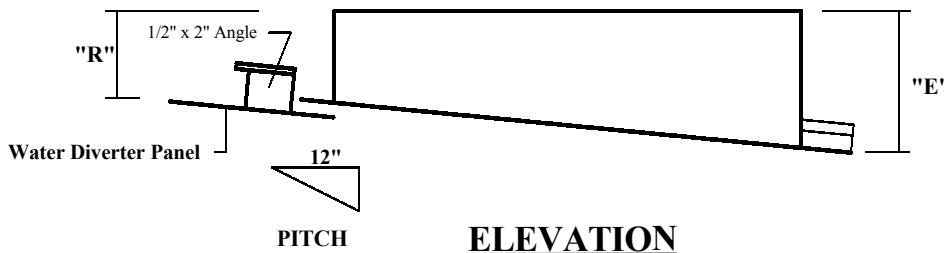

QUANTITY	INSIDE DIMENSION	OUTSIDE DIMENSION	"R"	"E"	"T"	TAG
	x	x				