

# RETAIL AIR SYSTEMS

P.O. Box 21532  
 Chattanooga, TN 37424  
 Phone: (800) 245-8104 Fax: (423) 553-1008

APPROVED BY: \_\_\_\_\_

DATE APPROVED: \_\_\_\_\_

## (DLPD) (Drum Louver) Plenum-Diffuser System

### STANDARD FEATURES

1. G-90, Galvanized Steel Construction.
2. Turning Vanes in Each Quadrant for Maximum Performance.
3. 1" Ultralite Fiber Duct Liner Insulation.
4. Vertical and Horizontal Adjustable Drum Louver.
5. Fully Assembled.
6. Standard Duct Connections Provided.
7. Wire Mounting Brackets Provided as Required.
8. Angles for Drop Ceiling Installation Available.
9. Engineered Curb and Duct Packages Available.

### OPTIONS

- 1.
- 2.
- 3.
- 4.

PROJECT NAME: \_\_\_\_\_

CITY, STATE: \_\_\_\_\_

CUSTOMER: \_\_\_\_\_

JOB NUMBER: \_\_\_\_\_

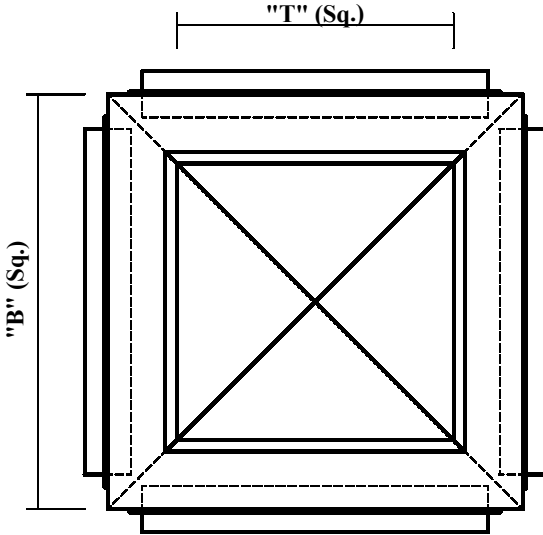

**PLAN VIEW**

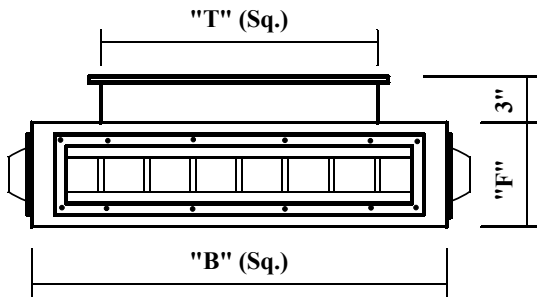
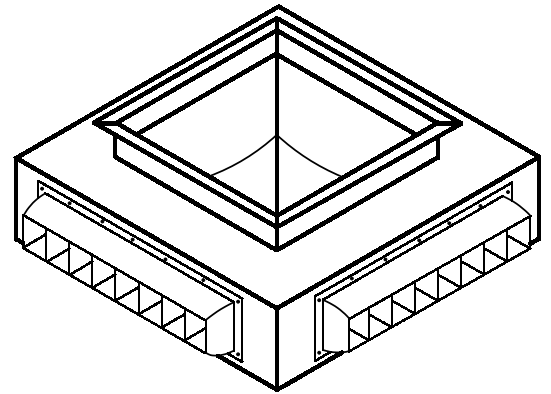

**ELEVATION**

QUANTITY	MODEL #	"T" (Sq.)	"B" (Sq.)	"F"	LOUVER SIZE	NOMINAL CFM	TAG
	DLPD 1206-5	14"	22"	9"	12-3/4" x 6-1/2"	2,000	
	DLPD 1806-7.5	20"	28"	9"	18-3/4" x 6-1/2"	3,000	
	DLPD 2406-10	22"	40"	9"	24-3/4" x 6-1/2"	4,000	
	DLPD 2010-12.5	24"	30"	13"	20-3/4" x 10-1/2"	5,000	
	DLPD 2510-15	28"	35"	13"	25-3/4" x 10-1/2"	6,000	
	DLPD 3510-20	30"	45"	13"	35-3/4" x 10-1/2"	8,000	
	DLPD 4010-25	36"	50"	13"	40-3/4" x 10-1/2"	10,000	
	DLPD 5010-30	38"	70"	13"	60-3/4" x 10-1/2"	12,000	